



FASTMAN

SCREW THREAD INSERTS



FASTMAN Screw Thread Inserts are made of helically coiled 18-8 stainless steel wire, with precise diamond shaped cross section to accommodate internal and external threads simultaneously. When assembled in a *FASTMAN* tapped hole, the *FASTMAN* Insert presents a permanent internal thread which conforms to standard specification.

THEY PROVIDE
PERMANENT THREADS
IN ANY MATERIAL
AND SOLVE PROBLEMS
OF PRODUCTION
& SALVAGE

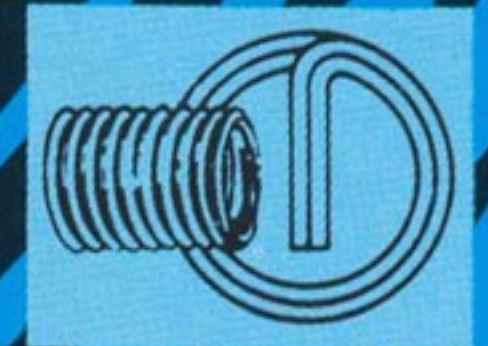

A PRODUCT OF

FASTENER MANUFACTURERS PRIVATE LIMITED

4, Mandeville Gardens, Calcutta-700 019, India Phones : 440-5544/6780 Gram : HELIFAST

LUCKNOW : Plot B3, Amausi Industrial Area, P.O. Amausi, Lucknow - 226008, Phone : 436676, Gram : HELIFAST.
BANGALORE : Plot 3D, Visveswaraya Industrial Area, 1st Stage, Bangalore - 560 048, Phone : 8511934

Bulletin : B 102

FASTMAN screw thread Inserts are made of helically coiled 18-8 stainless steel wire with a precise diamond shaped cross section to accommodate internal and external threads simultaneously. When assembled in a **FASTMAN** tapped hole the **FASTMAN** Insert presents a permanent internal thread which conforms to standard specifications. **FASTMAN** Inserts are available in two basic types-STANDARD (free running) and SCREW-LOCK (internal locking)

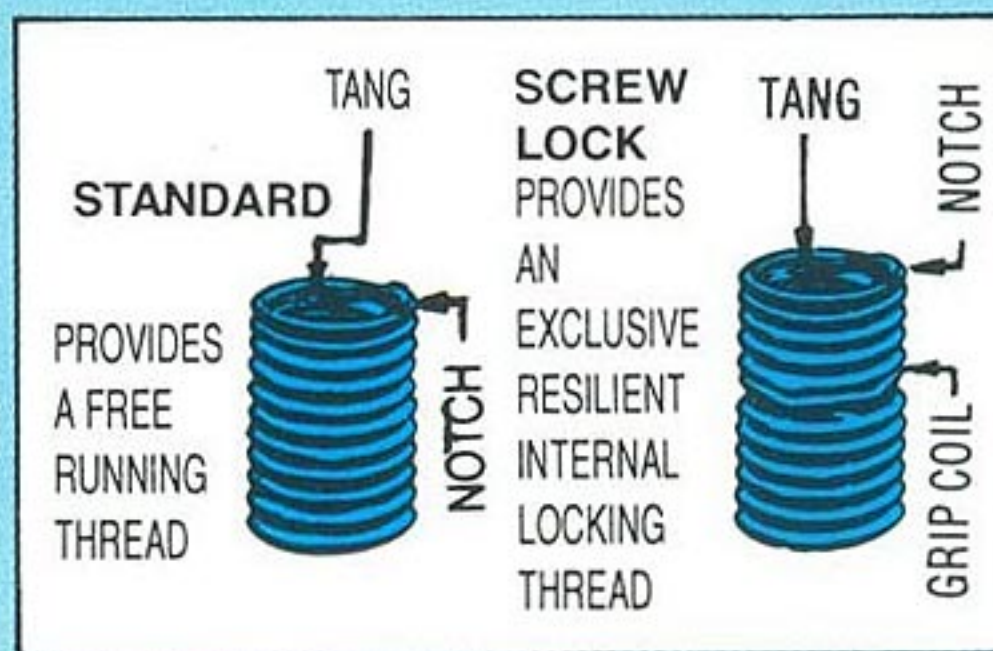
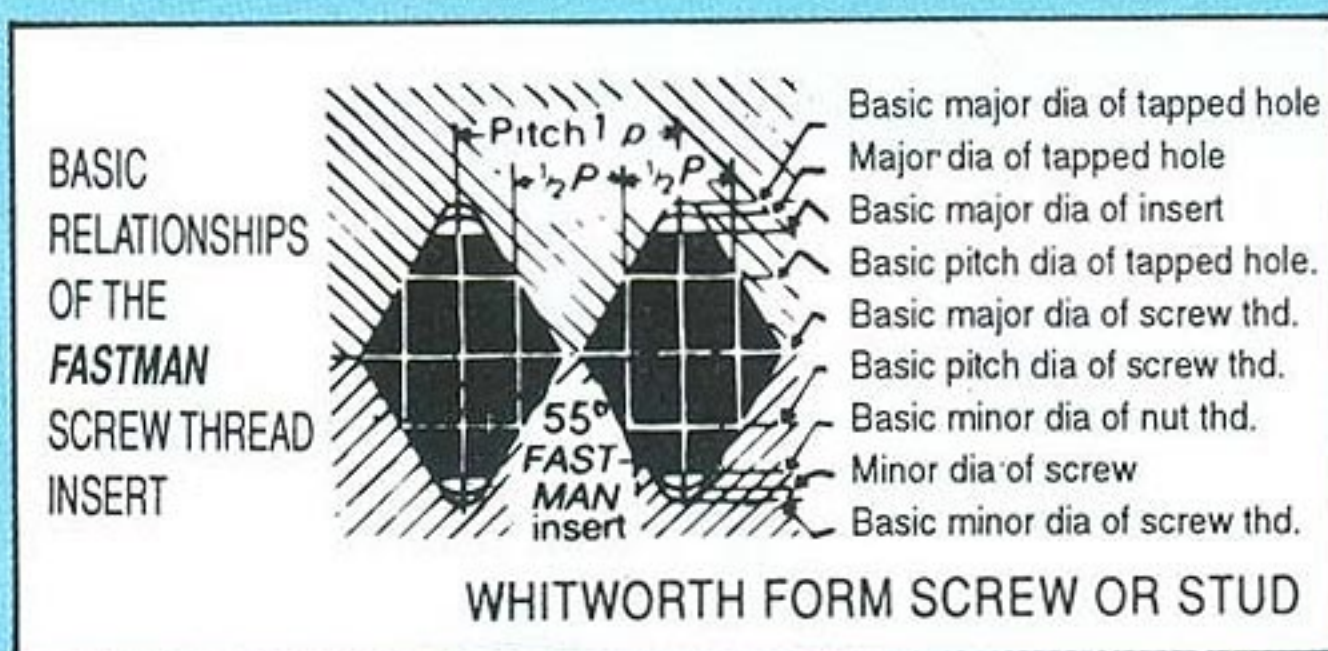

HOW TO ORDER- INSERT-Select Part No. from Cols 2 & 3 & add basic length of insert taken from Cols. 4 to 10 Example SL - C16CN X 24 represents

TOOLS - Simply state part Nos. of tools from column below

SCREW THREAD SERIES	NOMINAL THREAD SIZE		FASTMAN INSERT IDENTIFICATION NUMBER (For Stainless Steel Notched)		BASIC LENGTHS "Q" INCH Equal to length of minimum through hole, or minimum length of full form thread in blind hole. Actual length of assembled insert equals basic length less 1/2 pitch.				
	1	2	3	4	5	6	7	8	
B. S. W. SERIES	DIA	T.P.I.	STANDARD	SCREW LOCK	1 DIA	1 1/2 DIA	2 DIA	2 1/2 DIA	3 DIA
	1/8"	40	1255-2 CN	2455-2 CN		3/16	1/4	5/16	3/8
	3/16"	24	1255-3 CN	2455-3 CN	3/16	9/32	3/8	15/32	9/16
	1/4"	20	1255-4 CN	2455-4 CN	1/4	3/8	1/2	5/8	3/4
	5/16"	18	1255-5 CN	2455-5 CN	5/16	15/32	5/8	25/32	15/16
	3/8"	16	1255-6 CN	2455-6 CN	3/8	9/16	3/4	15/16	1 1/8
	7/16"	14	1255-7 CN	2455-7 CN	7/16	21/32	7/8	1 3/32	1 5/16
	1/2"	12	1255-8 CN	2455-8 CN	1/2	3/4	1	1 1/4	1 1/2
	9/16"	12	1255-9 CN	2455-9 CN	9/16	27/32	1 1/8	1 13/32	1 11/16
	5/8"	11	1255-10 CN	2455-10 CN	5/8	15/16	1 1/4	1 9/16	1 7/8
	11/16"	11	1255-11 CN	2455-11 CN	11/16	1 1/32	1 3/8	1 23/32	2 1/16
	3/4"	10	1255-12 CN	2455-12 CN	3/4	1 1/8	1 1/2	1 7/8	2 1/4
	7/8"	9	1255-14 CN		7/8	1 5/16	1 3/4	2 3/16	2 5/8
	1"	8	1255-16 CN		1	1 1/2	2	2 1/2	
	1 1/8"	7	1255-18 CN		1 1/8	1 11/16	2 1/4	2 13/16	
	1 1/4"	7	1255-20 CN		1 1/4	1 7/8	2 1/2	3 1/8	
1 1/2"	6	1255-24 CN		1 1/2	2 1/4	3			

B. S. F. SERIES	3/16"	32	1261-3 CN	2461-3 CN	3/16	9/32	3/8	15/32	9/16
	7/32"	28	1261-35 CN	2461-35 CN	7/32	21/64	7/16	35/64	21/32
	1/4"	26	1261-4 CN	2461-4 CN	1/4	3/8	1/2	5/8	3/4
	9/32"	26	1261-45 CN	2461-45 CN	9/32	27/64	9/16	45/64	27/32
	5/16"	22	1261-5 CN	2461-5 CN	5/16	15/32	5/8	25/32	15/16
	3/8"	20	1261-6 CN	2461-6 CN	3/8	9/16	3/4	15/16	1 1/8
	7/16"	18	1261-7 CN	2461-7 CN	7/16	21/32	7/8	1 3/32	1 5/16
	1/2"	16	1261-8 CN	2461-8 CN	1/2	3/4	1	1 1/4	1 1/2
	9/16"	16	1261-9 CN	2461-9 CN	9/16	27/32	1 1/8	1 13/32	1 11/16
	5/8"	14	1261-10 CN	2461-10 CN	5/8	15/16	1 1/4	1 9/16	1 7/8
	11/16"	14	1261-11 CN	2461-11 CN	11/16	1 1/32	1 3/8	1 23/32	2 1/16
	3/4"	12	1261-12 CN	2461-12 CN	3/4	1 1/8	1 1/2	1 7/8	2 1/4
	13/16"	12	1261-13 CN		13/16	1 7/32	1 5/8	2 1/32	2 7/16
	7/8"	11	1261-14 CN		7/8	1 5/16	1 3/4	2 3/16	2 5/8
	1"	10	1261-16 CN		1	1 1/2	2	2 1/2	
	1 1/8"	9	1261-18 CN		1 1/8	1 11/16	2 1/4	2 13/16	
1 1/4"	9	1261-20 CN		1 1/4	1 7/8	2 1/2	3 1/8		
1 3/8"	8	1261-22 CN		1 3/8	2 1/16	2 3/4			
1 1/2"	8	1261-24 CN		1 1/2	2 1/4	3			

SCREW THREAD SERIES	NOMINAL THREAD SIZE	TAPPED HOLE & FITTED SIZE DATA FOR FASTMAN INSERTS (See Diagrams above) INCH									
		1		9		10	11		12		13
		DIA	T.P.I.	A		B	C		D		E
		MAX.	MIN.	MIN.	MAX.	MIN.	MAX.	MIN.	MAX.	MIN.	
B. S. W. SERIES	1/8"	40	.135	.129	.1548	.1430	.1410	.1119	.1090	.0930	
	3/16"	24	.202	.196	.2365	.2166	.2142	.1643	.1608	.1341	
	1/4"	20	.267	.261	.3087	.2849	.2820	.2219	.2180	.1860	
	5/16"	18	.334	.328	.3777	.3512	.3480	.2811	.2769	.2413	
	3/8"	16	.398	.390	.4483	.4185	.4150	.3395	.3350	.2950	
	7/16"	14	.463	.453	.5212	.4871	.4833	.3966	.3918	.3461	
	1/2"	12	.525	.515	.5973	.5575	.5533	.4518	.4466	.3932	
	9/16"	12	.588	.578	.6600	.6201	.6158	.5144	.5091	.4557	
	5/8"	11	.663	.653	.7312	.6878	.6832	.5724	.5668	.5086	
	11/16"	11	.727	.717	.7938	.7505	.7457	.6351	.6293	.5711	
	3/4"	10	.791	.781	.8669	.8191	.8141	.6920	.6860	.6220	
	7/8"	9	.916	.906	1.0048	.9516	.9462	.8103	.8039	.7328	
	1"	8	1.044	1.031	1.1457	1.0859	1.0801	.9268	.9200	.8400	
	1 1/8"	7	1.186	1.171	1.2912	1.2227	1.2165	1.0407	1.0335	.9420	
	1 1/4"	7	1.311	1.296	1.4163	1.3479	1.3415	1.1659	1.1585	1.0670	
	1 1/2"	6	1.571	1.546	1.6936	1.6137	1.6067	1.4013	1.3933	1.2866	

B. S. F. SERIES	3/16"	32	.198	.192	.2247	.2098	.2075	.1708	.1675	.1475
	7/32"	28	.231	.225	.2612	.2442	.2416	.1995	.1959	.1730
	1/4"	26	.264	.257	.2957	.2774	.2747	.2291	.2254	.2008
	9/32"	26	.295	.288	.3270	.3088	.3059	.2605	.2566	.2320
	5/16"	22	.330	.323	.3662	.3447	.3416	.2875	.2834	.2543
	3/8"	20	.392	.385	.4340	.4104	.4070	.3474	.3430	.3110
	7/16"	18	.458	.450	.5030	.4767	.4730	.4066	.4019	.3663
	1/2"	16	.522	.513	.5736	.5440	.5400	.4650	.4600	.4200
	9/16"	16	.586	.577	.6362	.6067	.6025	.5277	.5225	.4825
	5/8"	14	.649	.640	.7091	.6752	.6708	.5847	.5793	.5336
	11/16"	14	.713	.703	.7717	.7379	.7333	.6474	.6418	.5961
	3/4"	12	.775	.765	.8478	.8082	.8033	.7025	.6966	.6432
	13/16"	12	.838	.828	.9104	.8708	.8658	.7651	.7591	.7057
	7/8"	11	.900	.890	.9817	.9384	.9332	.8230	.8168	.7586
	1"	10	1.044	1.031	1.1173	1.0697	1.0641	.9426	.9360	.8720
	1 1/8"	9	1.170	1.156	1.2551	1.2021	1.1962	1.0608	1.0539	.9828
	1 1/4"	9	1.295	1.281	1.3803	1.3274	1.3212	1.1861	1.1789	1.1078
	1 3/8"	8	1.420	1.406	1.5212	1.4616	1.4551	1.3025	1.2950	1.2150
1 1/2"	8	1.545	1.531	1.6464	1.5868	1.5801	1.4277	1.4200	1.3400	

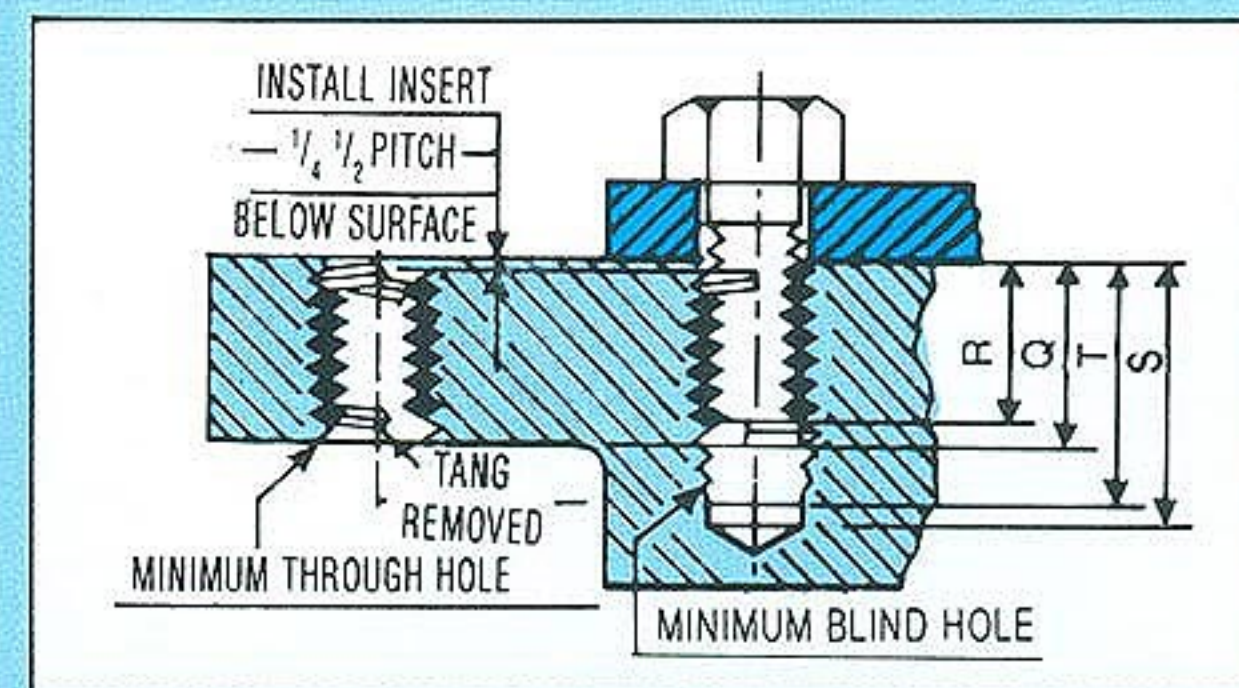
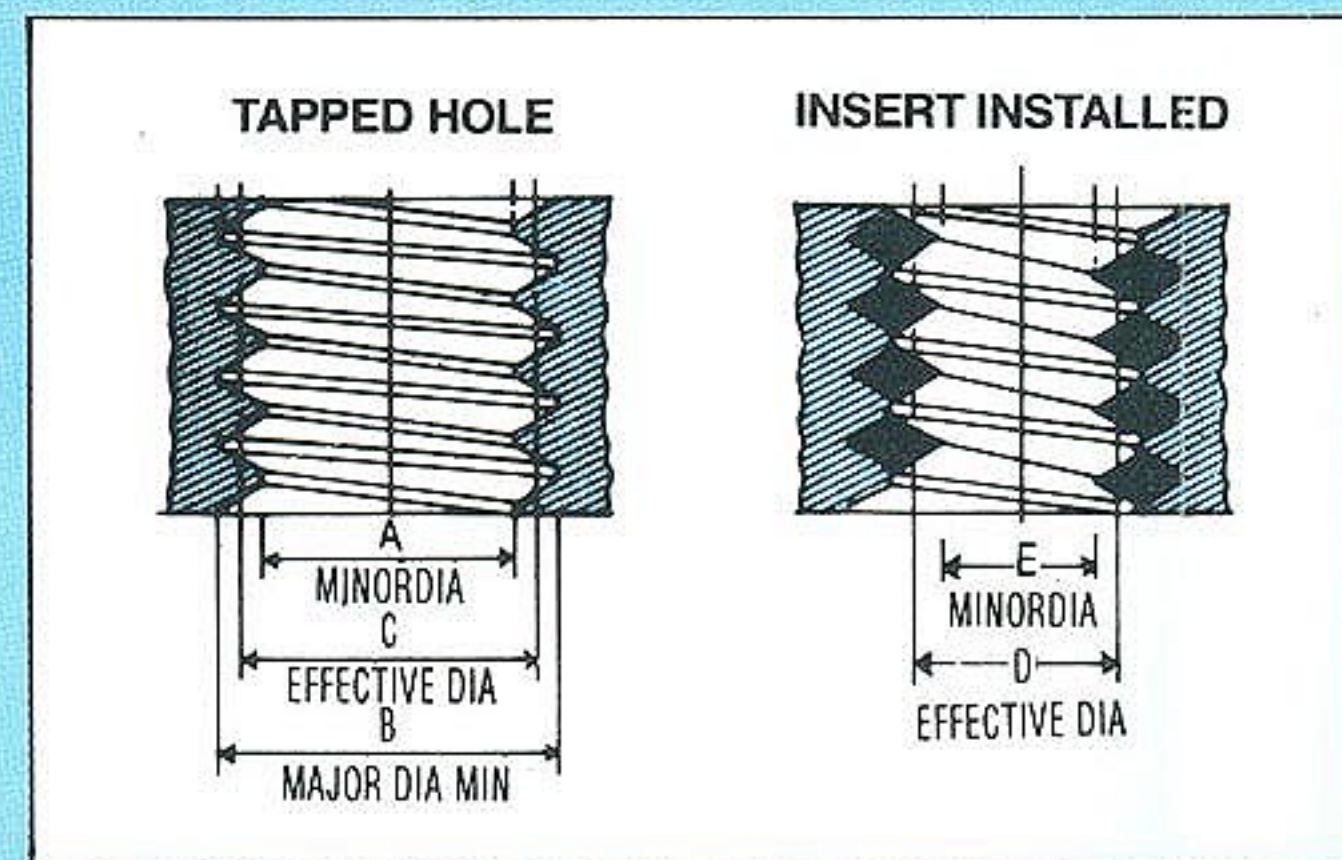

FORMULAE FOR CALCULATING MINIMUM DRILLING & TAPPING DEPTHS.

- P = PITCH in MM.
 - Q = Minimum full form tapped thread length. Values for Q are the same as the values listed in columns 4 to 8.
 - R = Entering portion of Screw (max.) if tang is not removed = Q-1P.
 - S = Drill Depth (min.) excluding point.
 - = Q + 4 1/2 P (if finishing taps are used).
 - or S = Q + 2 1/2 P (if bottoming taps are used)
 - T = Tap Depth (min.)
 - = Q + 3 1/2 P (if finishing taps are used)
 - or T = Q + 1 1/2 P (if bottoming taps are used).
- Depths of counterbores or countersinks, if any, must be added to values for Q, R, S & T.

SCREW THREAD SERIES	NOMINAL THREAD SIZE		DRILLS		TAPS			GAUGES	TOOLS			NOMINAL THREAD SIZE		SCREW THREAD SERIES	
	1	2	14	14A	15	16	17	18	19	20	21	22	23		
B. S. W. SERIES	DIA	T.P.I.	RECOMME- NDED SIZE	ALTERNATIVE SIZE	ROUGHING TAP	FINISHING PLUG TAP	FINISHING BOTTOMING TAP	FASTMAN GAUGE	PREWINDER TYPE INSERTING TOOL	TANG BREAK OFF TOOL	EXTRACT- ING TOOL	DIA	T.P.I.	B. S. W. SERIES	
	1/8"	40	#30	3.3 mm	2 WR	2 WP	2 WB	WGM-2	MWIP-2	MWTB-2	1227-06	1/8"	40		
	3/16"	24	# 9	5 mm	3 WR	3 WP	3 WB	WGM-3	MWIP-3	MWTB-3	1227-06	3/16"	24		
	1/4"	20	G	6.7 mm	4 WR	4 WP	4 WB	WGM-4	MWIP-4	MWTB-4	1227-6	1/4"	20		
	5/16"	18	21/64"	8.4 mm	5 WR	5 WP	5 WB	WGM-5	MWIP-5	MWTB-5	1227-6	5/16"	18		
	3/8"	16	25/64"	10 mm	6 WR	6 WP	6 WB	WGM-6	MWIP-6	MWTB-6	1227-6	3/8"	16		
	7/16"	14	29/64"	11.7 mm	7 WR	7 WP	7 WB	WGM-7	MWIP-7	MWTB-7	1227-16	7/16"	14		
	1/2"	12	33/64"	13.2 mm	8 WR	8 WP	8 WB	WGM-8	MWIP-8	MWTB-8	1227-16	1/2"	12		
	9/16"	12	37/64"	14.75 mm	9 WR	9 WP	9 WB	WGM-9	WIP-9	MWTB-9	1227-16	9/16"	12		
	5/8"	11	21/32"	16.75 mm	10 WR	10 WP	10 WB	WGM-10	WIP-10	MWTB-10	1227-16	5/8"	11		
	11/16"	11	23/32"	18.5 mm	11 WR	11 WP	11 WB	WGM-11	WIP-11	MWTB-11	1227-16	11/16"	11		
	3/4"	10	25/32"	20 mm	12 WR	12 WP	12 WB	WGM-12	WIP-12	MWTB-12	1227-16	3/4"	10		
	7/8"	9	29/32"	23.25 mm	14 WR	14 WP	14 WB	WGM-14	WIP-14	MWTB-14	1227-16	7/8"	9		
	1"	8	1 1/32"	26.5 mm	16 WR	16 WP	16 WB	WGM-16	WIP-16	MWTB-16	1227-16	1"	8		
	1 1/8"	7	1 11/64"	30 mm	18 WR	18 WP	18 WB	WGM-18	WIP-18	USE LONG- NOSED PLIERS	1227-24	1 1/8"	7		
	1 1/4"	7	1 19/64"	33 mm	20 WR	20 WP	20 WB	WGM-20	WIP-20		1227-24	1 1/4"	7		
	1 1/2"	6	1 35/64"	39.75 mm	24 WR	24 WP	24 WB	WGM-24	WIP-24		1227-24	1 1/2"	6		
B. S. F. SERIES	3/16"	32	#10	5 mm	3 XR	3 XP	3 XB	XGM-3	MXIP-3	MXTB-3	1227-6	3/16"	32		
	7/32"	28	# 1	5.8 mm	35 XR	35 XP	35 XB	XGM-35	MXIP-35	MXTB-35	1227-6	7/32"	28		
	1/4"	26	F	6.6 mm	4 XR	4 XP	4 XB	XGM-4	MXIP-4	MXTB-4	1227-6	1/4"	26		
	9/32"	26	L	7.4 mm	45 XR	45 XP	45 XB	XGM-45	MXIP-45	MXTB-45	1227-6	9/32"	26		
	5/16"	22	P	8.3 mm	5 XR	5 XP	5 XB	XGM-5	MXIP-5	MXTB-5	1227-6	5/16"	22		
	3/8"	20	W	9.8 mm	6 XR	6 XP	6 XB	XGM-6	MXIP-6	MXTB-6	1227-6	3/8"	20		
	7/16"	18	29/64"	11.5 mm	7 XR	7 XP	7 XB	XGM-7	MXIP-7	MXTB-7	1227-16	7/16"	18		
	1/2"	16	33/64"	13.2 mm	8 XR	8 XP	8 XB	XGM-8	MXIP-8	MXTB-8	1227-16	1/2"	16		
	9/16"	16	37/64"	14.75 mm	9 XR	9 XP	9 XB	XGM-9	XIP-9	XTB-9	1227-16	9/16"	16		
	5/8"	14	41/64"	16.5 mm	10 XR	10 XP	10 XB	XGM-10	XIP-10	XTB-10	1227-16	5/8"	14		
	11/16"	14	45/64"	18 mm	11 XR	11 XP	11 XB	XGM-11	XIP-11	XTB-11	1227-16	11/16"	14		
	3/4"	12	49/64"	19.5 mm	12 XR	12 XP	12 XB	XGM-12	XIP-12	XTB-12	1227-16	3/4"	12		
	13/16"	12	53/64"	21.25 mm	13 XR	13 XP	13 XB	XGM-13	XIP-13	XTB-13	1227-16	13/16"	12		
	7/8"	11	57/64"	22.75 mm	14 XR	14 XP	14 XB	XGM-14	XIP-14	XTB-14	1227-16	7/8"	11		
	1"	10	1 1/32"	26.25 mm	16 XR	16 XP	16 XB	XGM-16	XIP-16	XTB-16	1227-16	1"	10		
	1 1/8"	9	1 5/32"	29.5 mm	18 XR	18 XP	18 XB	XGM-18	XIP-18	USE LONG- NOSED PLIERS	1227-24	1 1/8"	9		
	1 1/4"	9	1 9/32"	32.75 mm	20 XR	20 XP	20 XB	XGM-20	XIP-20		1227-24	1 1/4"	9		
1 3/8"	8	1 13/32"	36 mm	22 XR	22 XP	22 XB	XGM-22	XIP-22	1227-24		1 3/8"	8			
1 1/2"	8	1 17/32"	39 mm	24 XR	24 XP	24 XB	XGM-24	XIP-24	1227-24		1 1/2"	8			

NOTES

DRILLS—Tapping drills listed in col. 14 are suitable for Aluminium. For Steel, Magnesium and Plastics, the alternative larger size drills (col 14A) should be used.

Taps—Finishing Taps (cols 16 & 17) will ordinarily produce both Medium & Close fits.

Gauges—Thread Plug Gauges (col. 18) are for Medium fit. These are used to check **FASTMAN** tapped holes before installation of the insert.

Inserting Tools—Prewinder type (col.20) recommends for all sizes of Inserts

Spark Plug— Inserts listed are suitable for 14 mm spark plugs according to Indian Standard Specification No. IS 1063 -1963

INSTALLATION PROCEDURE

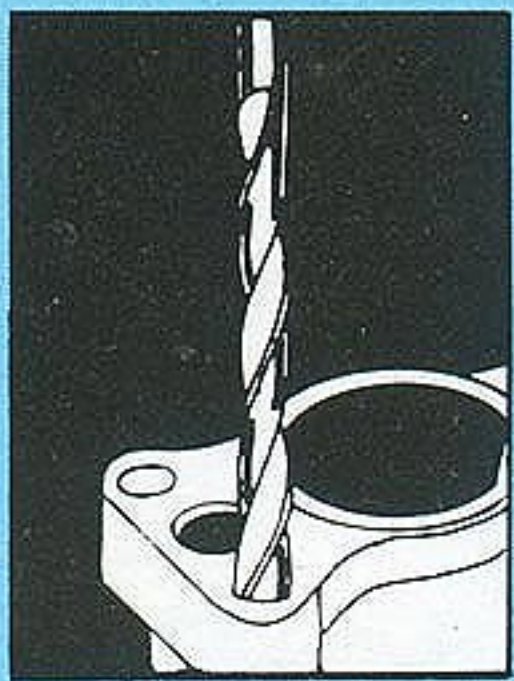

DRILLING

Use regular procedures, working to diameters specified in the Table on reverse. The first column is for Aluminium. For Steel, Magnesium and Plastics, the alternative larger size drills recommended in the second column should be used.

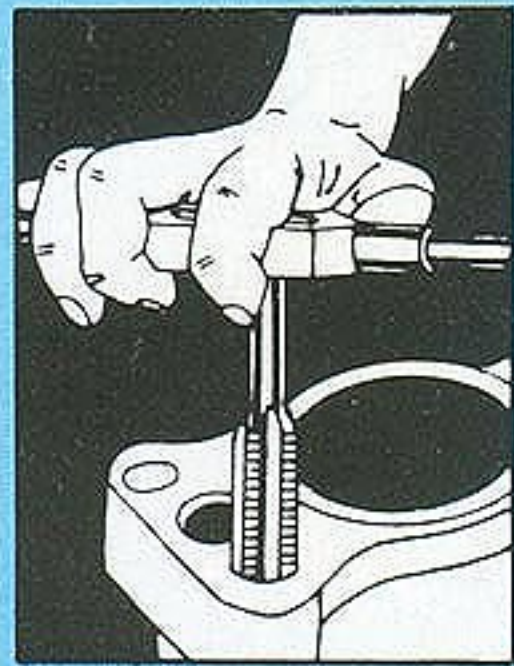

TAPPING

FASTMAN tapping is usually done in a single operation with one of the types of *FASTMAN* finishing taps. *FASTMAN* roughing taps are available, however, for occasions when tough materials make both rough and finish cuts necessary.

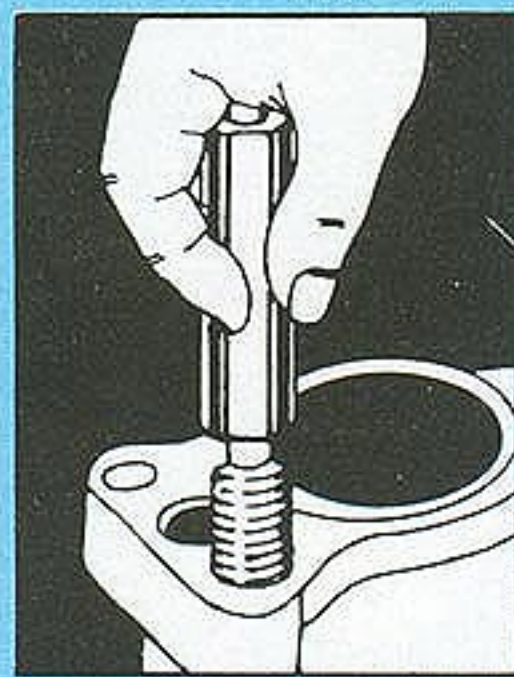

GAUGING

Clean tapped hole. Use required *FASTMAN* thread gauge to check size and full thread depth in conventional manner.

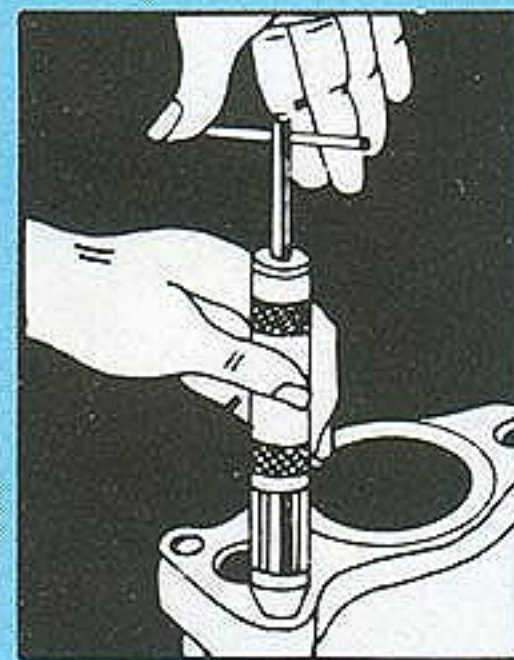

INSTALLING INSERTS

Prewinder Type *FASTMAN* Inserting Tools are available for hand installation of Inserts. The Prewinder Type is a precision tool which aligns and precompresses the insert for easy installation. A slotted mandrel in the tool drives the insert by its tang. This tool is recommended for hand installation of all sizes of Coarse & Fine Series of Inserts.

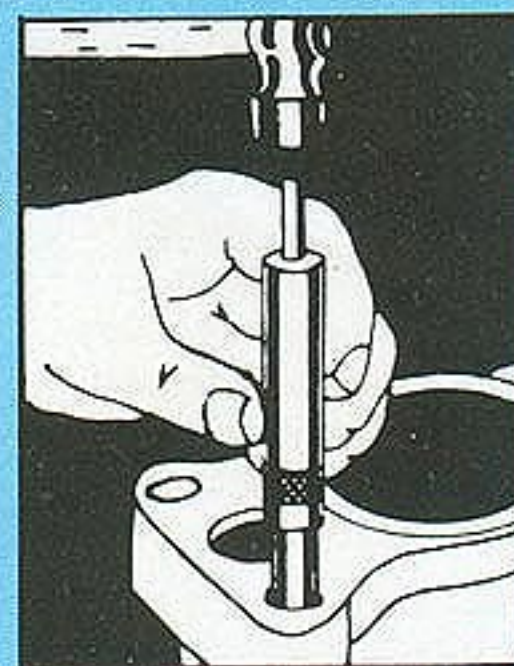

REMOVING INSERT TANGS

The tang on a *FASTMAN* Insert should be removed after installation only when necessary for screw clearance or product appearance, and in such cases notched inserts should be used. This is easily accomplished by placing the punch of the Tang Break Off Tool into the installed insert and resting tool squarely on the insert tang. Strike the top of the tool with a hammer, using a sharp blow. (Fig.4)



EXTRACTING INSERTS

In rare instances, inserts are installed too deep, cross-threaded or otherwise improperly inserted. Such inserts are readily removed with *FASTMAN* Extracting Tools which are available in four sizes to fit all sizes of inserts. Place the blade of the extracting tool into the insert as shown in Fig. 5. Hit the top of the tool with a hammer, causing the blade to bite into the insert. Push down on the tool and rotate counterclockwise to back the insert out of the hole.
(*FASTMAN* inserts produce permanent threads; hence extraction is not normally necessary.)

METHOD OF USING THE PREWINDER TYPE INSERTING TOOL

To use *FASTMAN* Prewinder Type Inserting Tool, (Fig.1) retract mandrel and place insert in chamber with tang end towards threaded tip of tool (Fig. 2). Advance the mandrel until slot fully engages the insert tang. Rotate and advance the mandrel until the mandrel protrudes 1 mm from tip. Hold tool firmly and squarely against work (Fig. 3) and install insert into tapped hole by rotating mandrel at a slow, uniform rate, until the top coil of the insert is $\frac{1}{4}$ to $\frac{1}{2}$ turn below top surface of hole. **DO NOT PUSH ON MANDREL. DO NOT REVERSE MANDREL TO REMOVE TANG.**

When inserts are installed in small parts which can be held in hand, the Inserting Tool should preferably be mounted in a vice and the work brought to the tool.

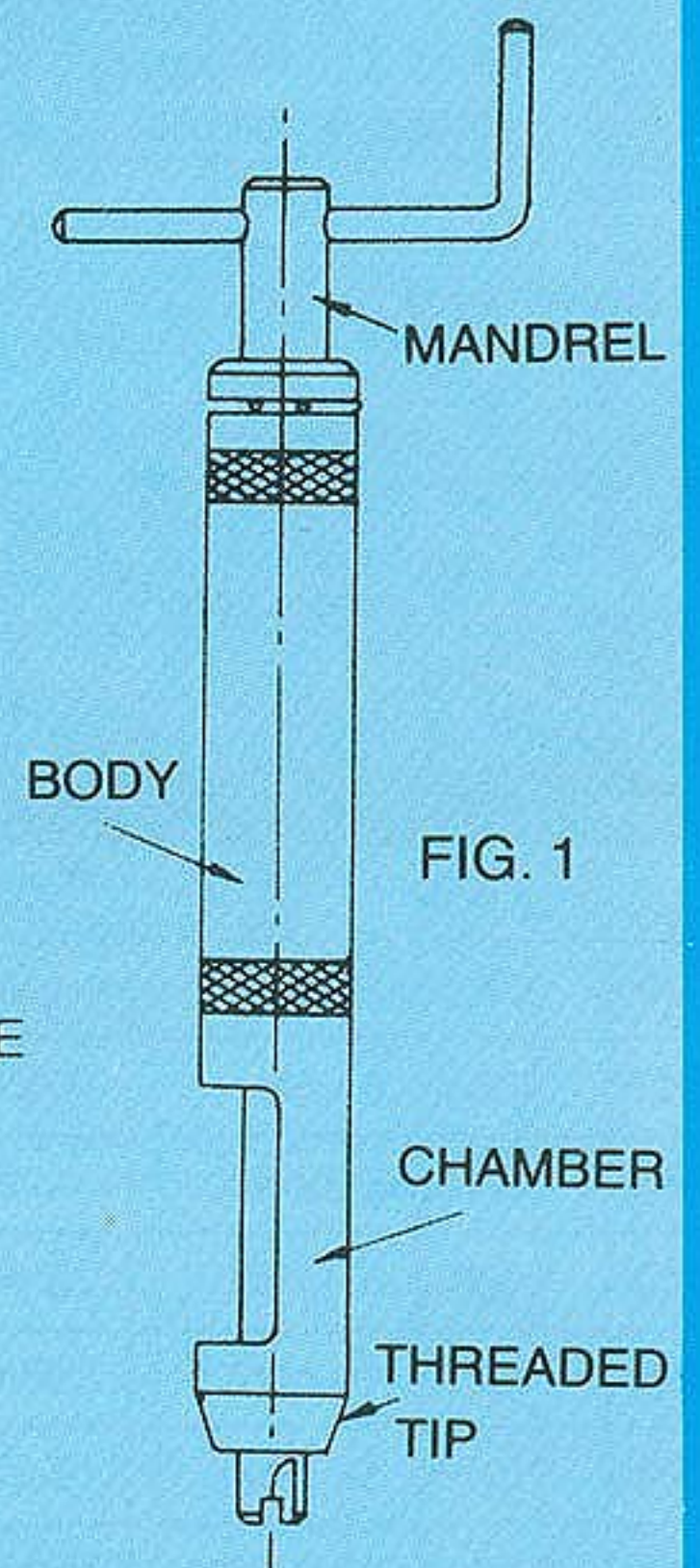

PREWINDER TYPE INSERTING TOOL

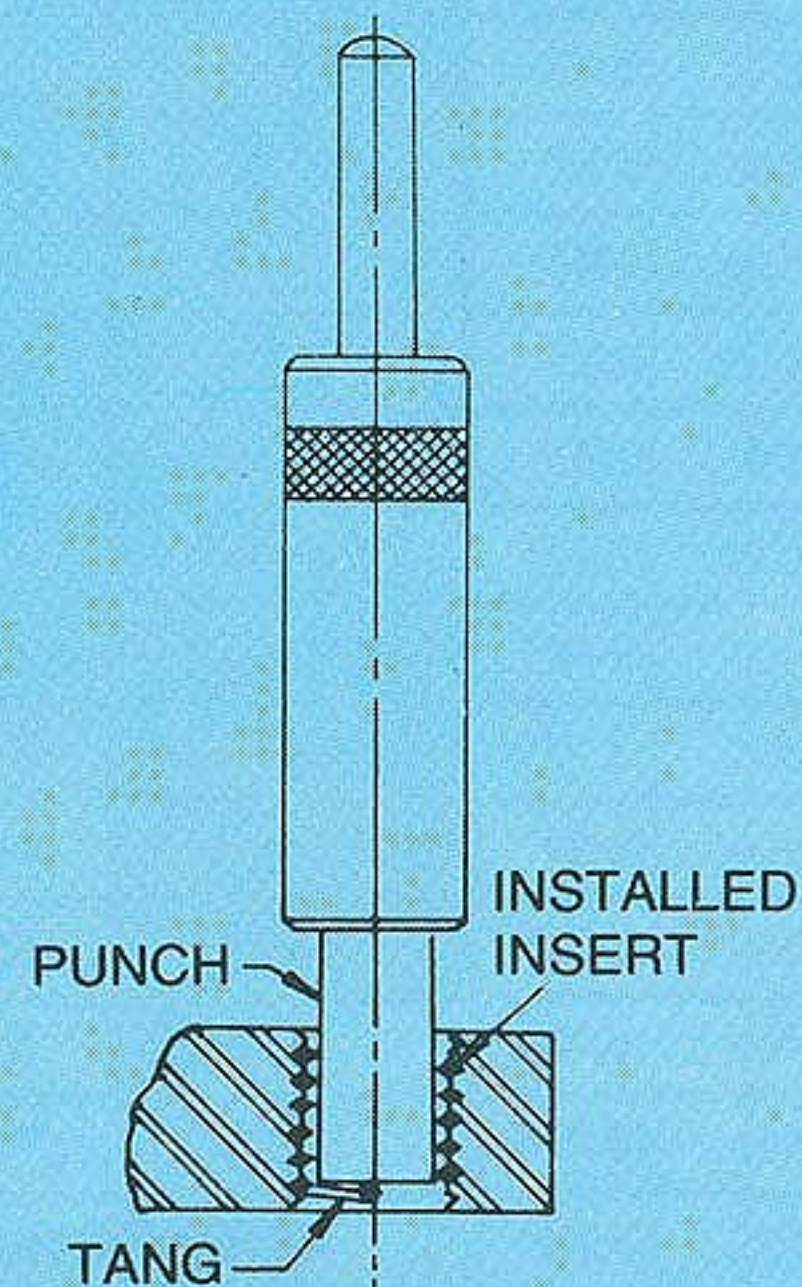
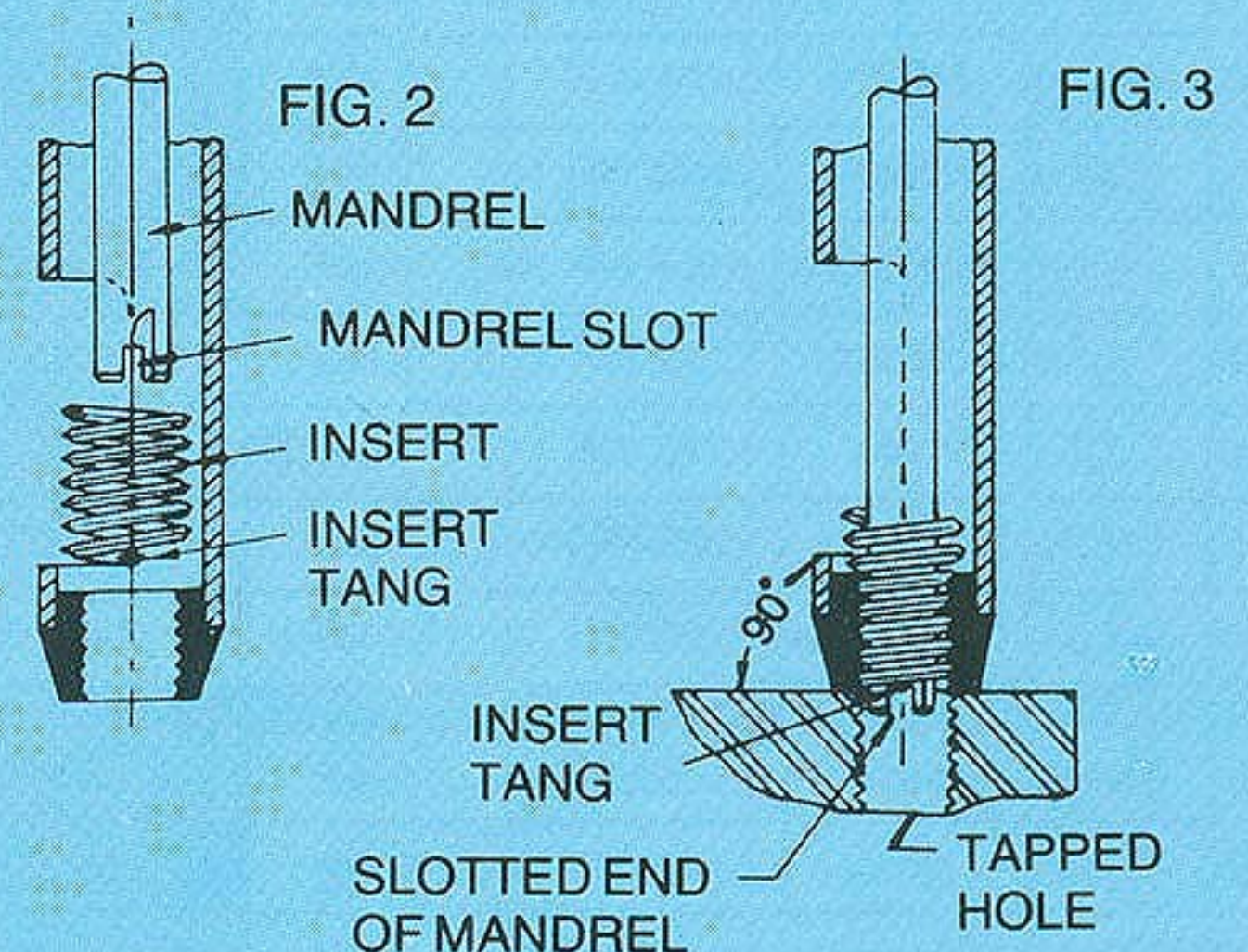

TANG BREAK-OFF TOOL

FIG. 4

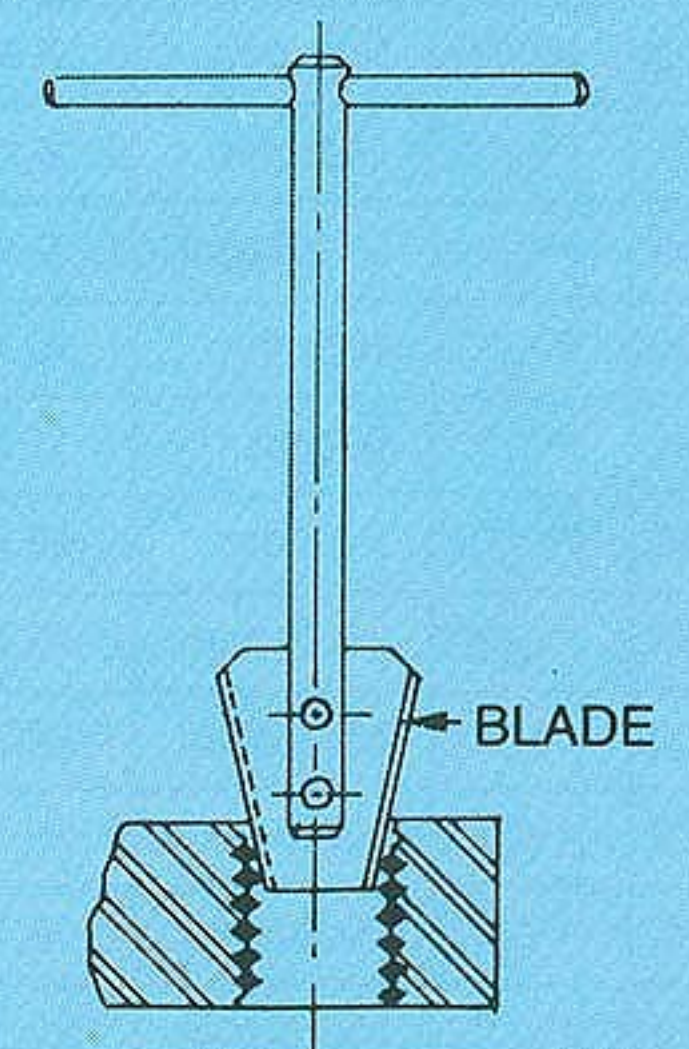

EXTRACTING TOOL

FIG. 5